

# SERVICE INFORMATION

## NO. SI 40NG-062

**NOTE:** SI's are used only:  
1) To distribute information from DAI to our customers.  
2) To distribute applicable information/documents from our suppliers to our customers with additional information.  
Typically there is no revision service for SI's. Each new information or change of that will be sent along with a new SI.

### I. TECHNICAL DETAILS

#### 1.1 Airplanes affected:

All DA 40 NG airplanes

#### 1.2 Subject:

Austro Engine Mandatory Service Bulletin No. MSB-E4-024/1  
ATA-Code: 71-00

#### 1.3 Reason:

Austro Engine has issued Mandatory Service Bulletin MSB-E4-024/1 prescribing the replacement of the standard circlip at the Waste Gate Controller at E4 engines with a spring loaded circlip.

#### 1.4 Information:

For detailed technical information refer to Austro Engine Mandatory Service Bulletin No. MSB-E4-024/1 which is applicable without any further additions or restrictions.

### II. OTHERS

Austro Engine Mandatory Service Bulletin No. MSB-E4-024/1 is attached to this Service Information.

In case of doubt contact Austro Engine GmbH



Service Bulletin  
No. MSB-E4-024/1

Austro Engine GmbH  
Rudolf-Diesel-Strasse 11  
2700 Wiener Neustadt  
PHONE: +43 2622 23000  
FAX: +43 2622 23000-2711

# MANDATORY SERVICE BULLETIN

## No. MSB-E4-024/1

SUPERSEDES RSB-E4-024

### 1. BASIC INFORMATION

#### 1.1. SUBJECT

Waste gate – Spring loaded circlip

#### 1.2. ENGINES AFFECTED

Engine type: E4  
Engine model(s): E4, E4P  
Serial number(s): all

#### 1.3. REASON

This Service Bulletin describes the replacement of the waste gate circlip, which prevents the waste gate actuator connection rod from disconnecting from the waste gate bolt of the turbo charger. An improved circlip design prevents the incorrect installation of the circlip.

#### 1.4. TIME OF COMPLIANCE

Within 300 flight hours from the issue date of this MSB, but not later than 31-Aug-2018

#### 1.5. CONCURRENT DOCUMENTS / REFERENCES

- Maintenance Manual E4 Series – Doc. No.: E4.08.04, latest effective issue
- Temporary Revision for Maintenance Manual E4.08.04: MM-TR-MDC-E4-386

#### 1.6. OTHER PUBLICATIONS AFFECTED

None.

First Issue Date			Rev. No.	Revision Date			Page
21	Jun	2017	1	31	Aug	2017	1-4

## 2. TECHNICAL DETAILS

### 2.1. ACCOMPLISHMENT / INSTRUCTIONS



Make sure MM-TR-MDC-E4-386 is inserted into the Maintenance Manual E4.08.04 or a revision of the MM with the Temporary Revision incorporated is used.

Replace the circlip DIN6799-5 with the spring loaded circlip E4A-41-100-801.

For removal and installation refer to Maintenance Manual E4.08.04.

### 2.2. ILLUSTRATIONS

Example: Turbo charger for engine configuration "-A" with new spring loaded circlip

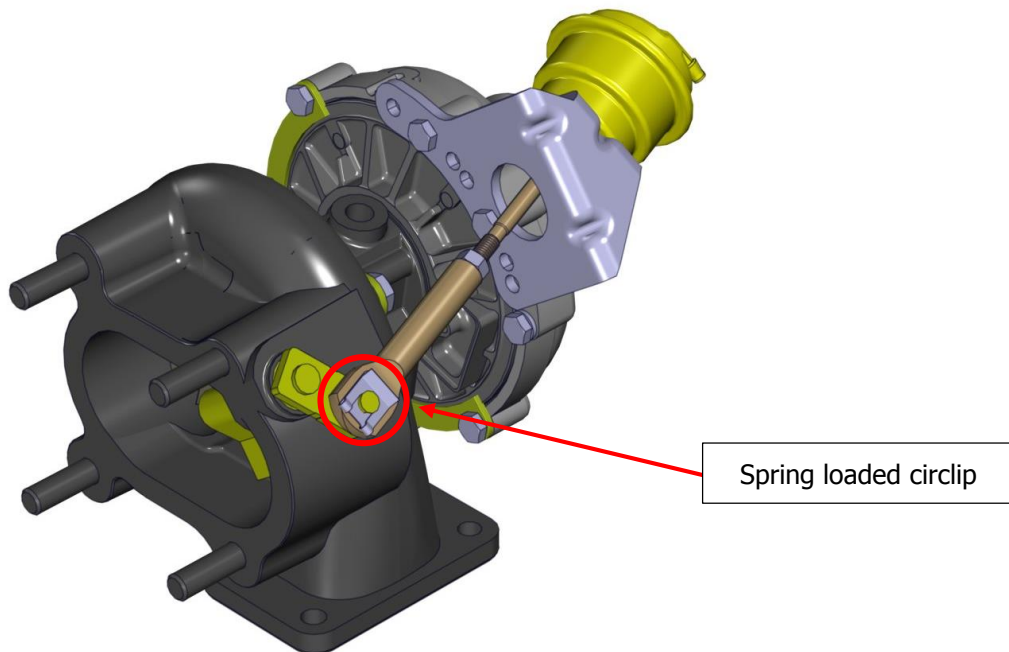

### 2.3. MASS (WEIGHT)

Not affected.

### 2.4. APPROVAL STATEMENT

The technical content of this document has been approved under the authority of DOA No. EASA.21J.399.

First Issue Date			Rev. No.	Revision Date			Page
21	Jun	2017	1	31	Aug	2017	2-4



Service Bulletin  
No. MSB-E4-024/1

Austro Engine GmbH  
Rudolf-Diesel-Strasse 11  
2700 Wiener Neustadt  
PHONE: +43 2622 23000  
FAX: +43 2622 23000-2711

### 3. PLANNING INFORMATION

---

#### 3.1. MATERIAL & AVAILABILITY

Amount	Part Name	Part number	Rev. number
1	Spring loaded circlip	E4A-41-100-801	AA1 or higher

#### 3.2. SPECIAL TOOLS

None.

#### 3.3. LABOR EFFORT

Not specified.

### 4. REMARKS

---

#### **NOTE:**

- All measures must be carried out by a certified engine station and certified engine mechanics.
- The accomplishment of the instructions shown under chapter 2.1 must be confirmed in the respective engine log book.
- The accomplishment of the instructions must be carried out within the time of compliance according chapter 1.
- In case of doubt please contact the Austro Engine GmbH – After Sales Support (e-mail: [service@austroengine.at](mailto:service@austroengine.at); Tel: +43 2622 23000 2525).
- For credit information contact Austro Engine GmbH – After Sales Support (e-mail: [service@austroengine.at](mailto:service@austroengine.at); Tel: +43 2622 23000 2525)

First Issue Date			Rev. No.	Revision Date			Page
21	Jun	2017	1	31	Aug	2017	3-4



## 5. EXPLANATORY NOTES

---

### 5.1. SYMBOL EXPLANATION



**WARNING:** Disregarding these safety rules can cause personal injury or even death



**CAUTION:** Disregarding these special instructions and safety measures can cause damage to the engine or other components.



**NOTE:** Additional note or instruction for better understanding of an instruction

## 6. APPENDIX

---

None.

First Issue Date			Rev. No.	Revision Date			Page
21	Jun	2017	1	31	Aug	2017	4-4